

# Instructions for Large AC Motors - Horizontal Frames 504 through 688.5 - Dripproof Construction Squirrel Cage and Wound Rotor - Ball or Sleeve Bearing



I.L. 3100-24

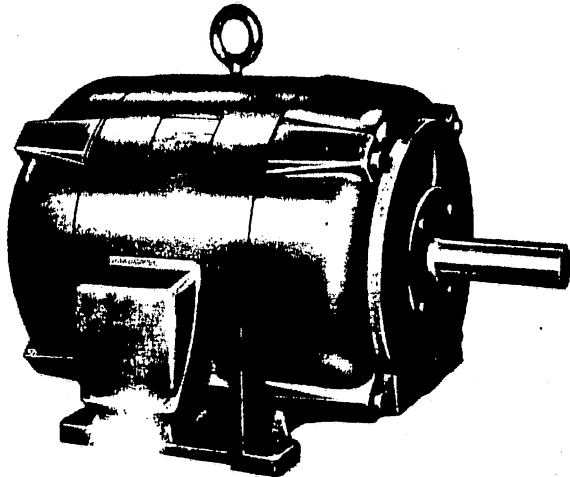

Figure 1 A-C Motor Frames 504 to 509

LIFE-LINE® Squirrel-Cage Induction Motors are designed for a wide variety of constant speed applications.

Life-Line wound rotor induction motors are designed for a wide variety of variable speed or constant speed applications where high starting torque with low starting current is a requirement, such as accelerating a high inertia drive.

The frames are of cast iron on the 504 through 509 frames and of fabricated steel on the 584 through 688.5 frames. All brackets are of cast iron.

## STANDARD WARRANTY

Westinghouse warrants that the equipment delivered by it will be of the kind and quality described in the order or contract and will be free of defects in workmanship or material. Should any failure to conform to this warranty appear within one year after date of initial operation, not to exceed 18 months after date of shipment, Westinghouse shall, upon prompt notification from the purchaser, and pro-

vided that (1) the equipment has been stored, installed, operated and maintained in accordance with the order or contract, generally acceptable industry practices and Westinghouse instructions, and (2) that the equipment has not been subjected to alteration, misapplication or misuse, correct such nonconformity by repair or replacement f.o.b. point of shipment, of the nonconforming part or parts. Westinghouse shall not be responsible for providing working access to the defect. Correction of nonconformities, in the manner and for the period of time provided above, shall constitute fulfillment of all liabilities of Westinghouse with respect to the quality of the equipment.

The foregoing warranty is exclusive and in lieu of all other warranties of quality whether written, oral, or implied including any warranty of merchantability or fitness for purpose.

Any defects that may develop should be referred to the nearest Westinghouse Sales Office for complete servicing information.

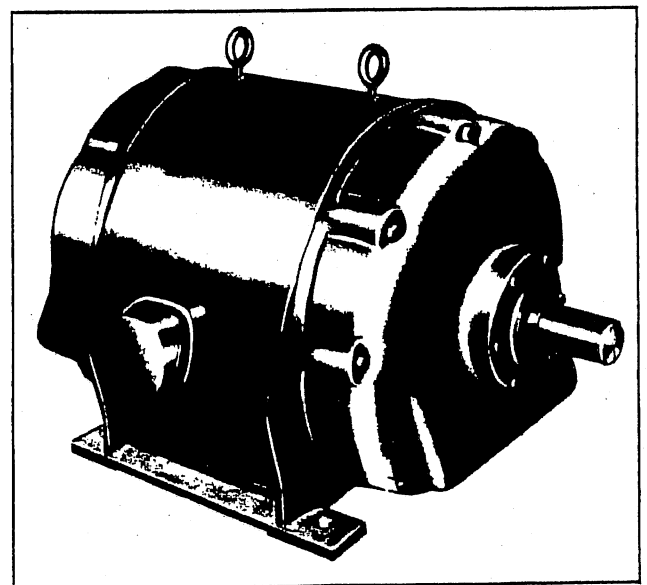

Figure 2 A-C Motor Frames 584 to 688.5

## Unauthorized Repairs

In the event that the customer sends his motor to an unauthorized Repair Shop, the coverage of this warranty policy is automatically terminated.

## RECEIVING

Unpack the motor and make certain that it was not damaged during shipment. Check to see that the nameplate data agrees with the voltage and frequency of the power supply provided for the motor.

The shaft extension may be coated with a slushing compound to prevent rusting during shipment and storage. This slushing compound may be removed by wiping with turpentine or a petroleum solvent, such as benzine, gasoline, Stoddard solvent, etc. See precautions under "Maintenance" for use of these solvents.

## STORAGE

If motor must be stored temporarily, place it under cover in a clean dry location; it is recommended that space heaters or other reliable heating means be used to protect windings from excessive moisture absorption. Bearing oil reservoirs should be filled with a good grade of rust inhibiting oil and shaft should be rotated at one month intervals. See also page 5, Moisture.

If storage is to be prolonged, motor should be prepared for long-term storage; refer to nearest Westinghouse Sales Office for assistance.

## INSTALLATION

### Mounting

Locate the motor in a place that is clean, dry and well-ventilated. If protecting shields or guards are used, they must not obstruct the free flow of air around the motor. The external air temperature should not exceed 40°C or 104°F unless the motor has been specially designed or otherwise cleaned for use in higher ambient.

Fasten to a rigid foundation using bolts or screws of the largest size permitted by the drilling in the mounting feet. The motor must rest evenly on all mounting pads.

Install motors on a non-combustible surface. Never install where hazardous, inflammable or combustible vapors or dust are present.

After lineup is complete, dowel motor to the foundation using one dowel bolt in each of two diagonal feet.

For wall or ceiling horizontal mounting of "Ball Bearing Motors" the brackets must be turned through 90 or 180° to keep surplus grease sump below shaft. For wall or ceiling horizontal mounting of "Sleeve Bearing Motors" the brackets must be turned 90 or 180° to keep oil reservoir below the shaft.

### Method of Drive

Motors having the suffix "-S" or "-H" following the frame number are suitable for direct coupled service only. Motors having the suffix, "C, D, U, or Z" are suitable for Belt, Gear or Chain Drive.

### NOTE

Coupling halves, pulleys, pinions or sprockets should fit tight on the shaft extension to avoid hammering out in operation. If it is necessary to drive the part into position, it is important that the end of the shaft opposite the extension be backed up so that the force of the blow is not taken in the bearing. Use a pinion puller for removing tight pulleys, couplings or sprockets.

1. Direct Drive. The motor shaft and driven shaft must be carefully aligned using dial indicators.

2. Belt Drive. Mount the motor on slide rails or a bedplate which allows for adjusting the belt tension. Mount the motor pulley close to the bearing housing, allowing sufficient clearance for rotor end play.

Align the pulleys so that the belt runs true, and tighten the belt just enough to prevent slippage. The slide rails should be located so that the motor is near the end of the slot closest to the driven machine. This permits maximum adjustment for belt stretch.

NOTE

Not all motors are suitable for belt drive. Refer to the nearest Westinghouse Sales office for maximum HP and speeds that can be belt driven.

3. Gear Drive. Mount the motor and driven unit so as to maintain accurate alignment. The gears must mesh accurately to prevent vibration. Mount the motor gear close to the bearing housing to minimize the overhang, allowing sufficient clearance for rotor end play. Dowel the motor to the base.

4. Chain Drive. Mount the motor on slide rails or a bedplate which allows for adjusting the chain tension. Mount the motor sprocket close to the bearing housing, allowing sufficient clearance for rotor end play, and align the sprockets accurately.

Electrical Connections

Be sure the motor is connected as shown on the nameplate diagram, and that the power supply (Voltage, Frequency and Number of Phases) corresponds with the nameplate data.

Connect to the power supply through a suitable switch and overload protection.

Install all wiring and fusing in accordance with the National Electric Code and local requirements.

To change the direction of rotation on three-phase motors, interchange any two line leads.

To change the direction of rotation on two-phase 4-wire motors, interchange the line leads of either phase. To change the

direction of rotation on 2-phase 3-wire motors, interchange the two outside leads.

NOTE

If the direction of rotation is indicated on the motor and it is desired to operate in the opposite direction, it will be necessary to change the blowers as unidirectional blowers have been used. Refer to the nearest Westinghouse Sales Office for assistance.

For Wound Rotor Motors - Check the secondary voltage on nameplate with control and with service expected. Motors with secondary voltage above 300 volts should not be connected to a reversing controller.

Connect primary leads to the power supply through a suitable switch and overload protection. Connect secondary leads to the controller.

Conduit Box

If the conduit box is desired on the opposite side of the motor, remove the brackets and rotor, reverse the frame, and reassemble.

The conduit box may be rotated 90° or 180° for use with horizontal conduit or conduit from above.

When the motor is mounted on a bedplate or slide rails for belt adjustment, flexible metallic conduit should be used to protect the leads to the motor. In making this connection a squeeze connector should be used for attaching the flexible conduit to the conduit box. Squeeze connectors may be straight, 45° or 90°.

OPERATION

Never start a wound rotor motor without secondary resistance in the circuit or brushes and collector rings will be burned and pitted.

For wound rotor motors, check the brushes and brushholders to be sure brushes are making contact with the slip rings and

are free to move in the holders before applying power to operate the motor.

Run the motor without load to check the connections and direction of rotation.

The motor will operate satisfactorily with a 10% variation in voltage, a 5% variation in frequency, or a combined voltage and frequency variation of 10%, but not necessarily in accordance with the standards of performance established for operation at normal rating. To stop motor refer to instructions furnished with the starter. Before starting sleeve bearing motors see instructions on page 9 under operation and care of sleeve bearings. Before starting oil lubricated ball bearing motors see instructions on page 8.

Repeated starts or jogs greatly reduce the life of the winding (See NEMA Standards MG1-20.43).

## MOTOR MAINTENANCE

Although Life-Line motors require a minimum of attention in service, they should be inspected at regular intervals to guard against excessive (1) dirt, (2) moisture, (3) friction and (4) vibration, which account for 90% of all motor failures.

### Cleanliness

Keep the insulation and mechanical parts of the motor clean. Dust that is free from oil or grease may be removed by wiping with a clean, dry cloth, or preferably, by suction. Suction is recommended over blowing out because it eliminates the danger of blowing metal chips and etc., into the insulation and also because of the danger of moisture in the compressed air. Dust may be blown from inaccessible parts with clean, dry air of moderate pressure.

When grease or oil is present, wipe with a cloth moistened (but not dripping) with a petroleum solvent of a "safety type" such as Stoddard solvent or similar materials available under various trade names.

Petroleum solvents are flammable and comparatively nontoxic.

### Moisture

Drip-proof motors should always be guarded against the accidental intrusion of water from splatter or splashing.

Stand-by motors should be run at least once a week to guard against moisture condensation.

Before starting motors which have been subjected to moisture, megger with a 500 volt megger. If resistance is below 2 megohms dry the winding in oven or circulate safe current. Continue drying until resistance rises to 2 megohms or preferably higher. Drying time will depend on size of machine and amount of moisture absorbed.

### Friction

Excessive friction or overheating of bearings is usually traced to one of the following causes:

- a. Excessive belt tension.
- b. Poor alignment causing excessive vibration or binding.
- c. Overgreasing.
- d. Insufficient lubricant.
- e. Excessive end or side thrust due to gearing, flexible coupling, etc.

### Vibration

To avoid failures due to vibration, a few simple checks should be made regularly.

Check for misalignment such as may be caused by foundation settling or heavy floor loading.

Check to see if vibration from the driven machine is being transmitted to the motor.

Check for excessive belt or chain tension or the push-apart effect inherent in spur gears.

Check the motor mounting bolts and bracket bolts to be sure they are tight.

Check motor mounting rails for looseness or system resonance.

#### Coils

Revarnishing the windings when motors are overhauled will lengthen their life. Suitable varnish may be obtained from the nearest Westinghouse Sales Office.

#### FOR WOUND ROTORS ONLY

Guard Against Excessive Brush Wear. Excessive brush wear may result from brushes too tight in holders. A free sliding fit should be maintained between brushes and brushholders by cleaning both when necessary.

Brushes should make good contact with the slip rings along the whole face of the brush. If necessary grind by attaching a strip of sandpaper to the slip rings with gummed tape on one end and turn the motor over slowly by hand. Use care to remove dust from motor. Maintain the brush spring tension at the correct value. A correct pressure per square inch is between 2 and 3

pounds for carbon or graphite brushes and between 3 and 5 pounds for metallic brushes, the lower pressure being favored in each case if a good brush to slip ring contact is obtained. Each brush should bear equal pressure.

NEVER LUBRICATE BRUSHES OR SLIP RINGS. Use the correct grade and size of brush which may be obtained by contacting the nearest Westinghouse Sales Office.

Guard Against Grooved, Rough, or Eccentric Slip Rings. Slip rings should be maintained smooth and true but not necessarily at a bright metallic color (brown oxide color indicates good brush and slip ring life). Grind or turn slip rings if necessary to restore a smooth and true surface.

If slip rings become pitted or burned check for improper functioning of secondary control or for open in motor rotor circuit.

#### GREASE LUBRICATED BALL BEARINGS (1800 RPM and Below)

#### Inspection

When the motor is installed make certain that the motor turns easily, particularly if the motor is not installed until some months after being shipped.

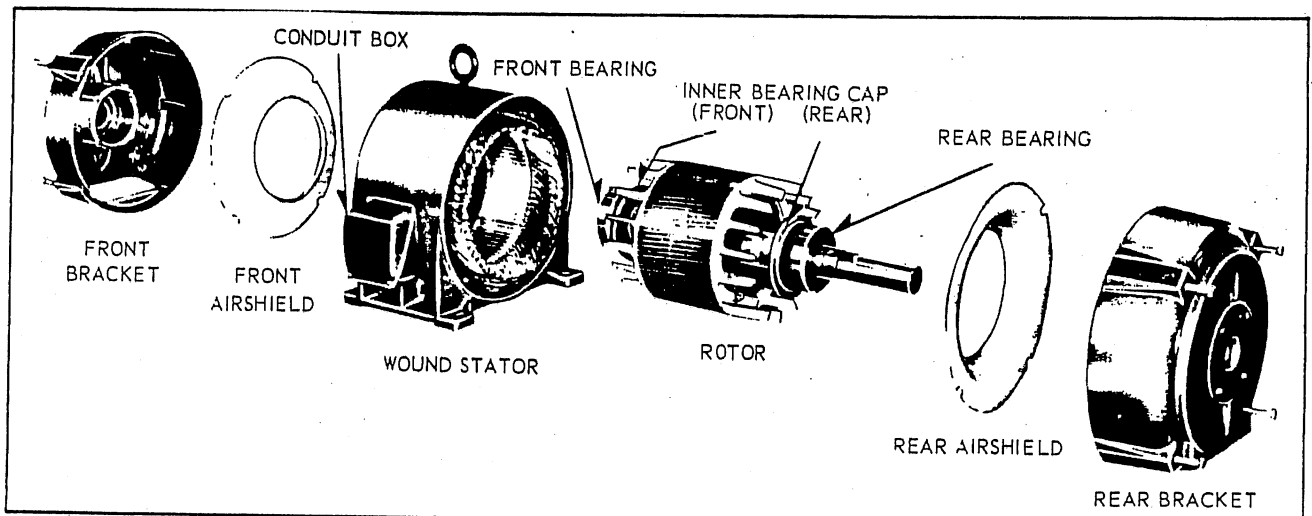

Figure 3 Arrangement of Parts Dripproof CSP Motors

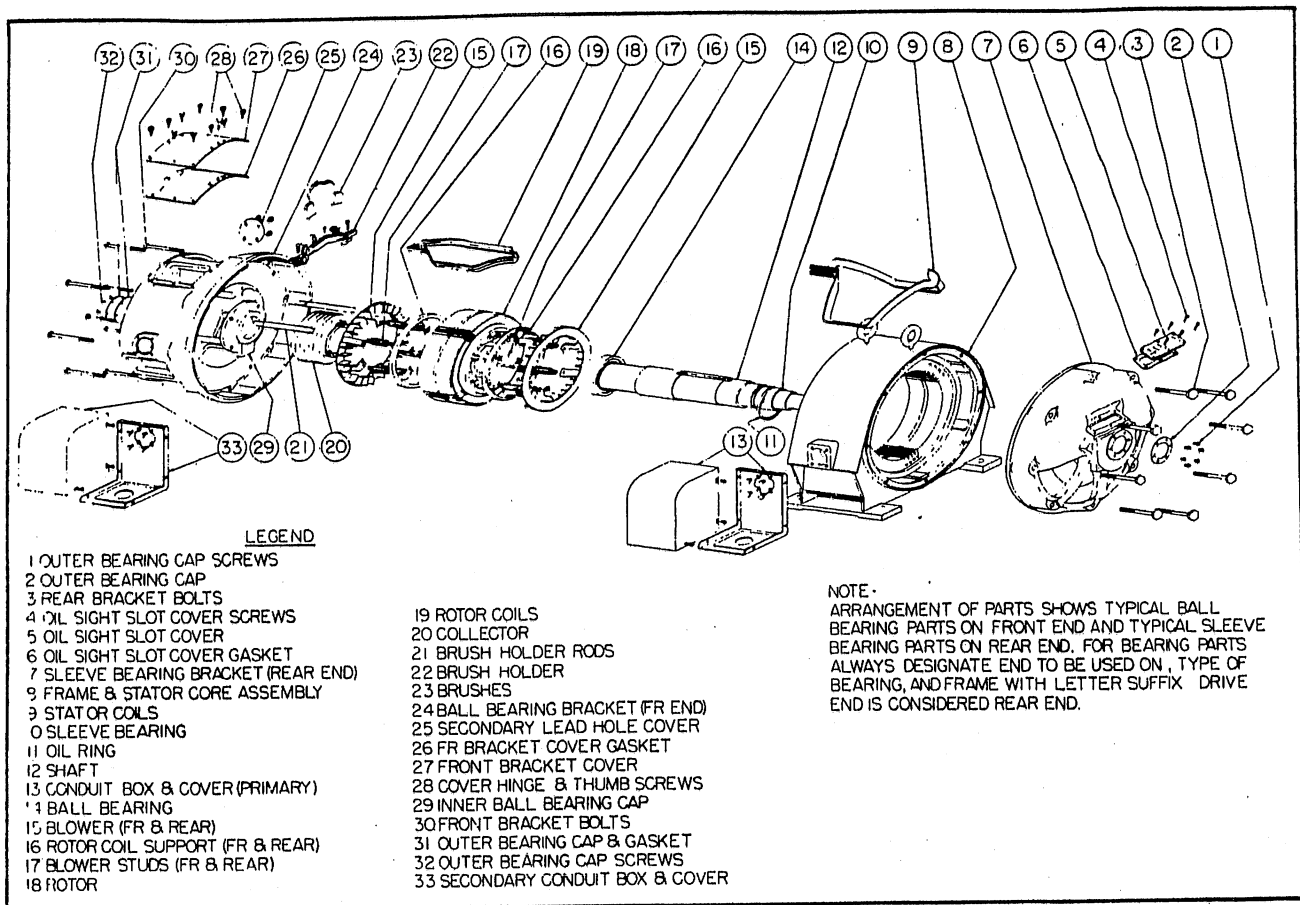

Figure 4 Arrangement of Parts - Dripproof CSP Motors (Wound Rotor)

External inspection after the motor is put into operation will determine whether the bearings are operating quietly and without undue heating. Further inspection will not be necessary except at infrequent intervals, probably at greasing periods.

#### Regreasing

Too much grease will cause churning, overheating and grease leakage. Guard against introduction of dirt when regreasing by keeping fittings clean at all times.

If high pressure guns are used, great care should be taken to avoid overlubrication.

When shipped from the factory, grease lubricated ball bearing motors have sufficient grease of the right grade to last for a limited period. However, a charge of grease should be added soon after the motor is put into operation and thereafter

at suitable intervals, as determined by experience.

#### NOTE

Some motors for special applications (such as motors exposed to higher than normal temperature conditions) will require a special grade of grease. These motors will be identified by having a special nameplate giving special greasing instructions. In such cases do not use the standard grease.

When regreasing the motor it is preferable to stop the motor. To regrease, proceed as follows: Remove drain plug - add new grease - operate motor for at least ten minutes to allow excess grease to drain out - replace drain plug. On motors using long grease pipes, the pipes should be cleaned to remove any hardened grease. This applies to both inlet and outlet pipes.

It is desirable for the most satisfactory service, to open the bearing housing once a year, or after every 5000 hours operation, to check the condition of the housing and grease. If difficult to inspect the pulley or pinion end bearing, the condition of the bearing at the opposite end will usually be representative of both. If grease deterioration has occurred or if dirty, the bearing and housing parts should be thoroughly cleaned out and new grease added.

Clean with suitable solvent such as Trichloroethylene. In some cases, it may be necessary to entirely remove the bearing from the shaft to clean it properly. For disassembly of the bearing housing see notes under "Removal of Brackets and Removal of Bearings".

As a guide to the amount of grease to be added and the frequency of greasing, see the following charts.

#### Greasing Schedule

<u>Method of Drive</u>	<u>Hours Operation</u>	<u>Greasing Intervals</u>		
		<u>8 Hr. Day</u>	<u>16 Hr. Day</u>	<u>24 Hr. Day</u>
Belt, Chain or Gear (1800 RPM or less)	1000	4 Mo.	2 Mo.	1-1/3 Mo.
Coupled (1800 RPM or less)	2000	8 Mo.	4 Mo.	2-1/3 Mo.
Coupled (3600 RPM)	1000	4 Mo.	2 Mo.	1-1/3 Mo.

Note: For severe dirt, weather exposed, high humidity or high ambient, cut time intervals to 1/2 of the above schedule.

#### Guide to Amount of Grease

<u>Shaft Diameter at Bracket</u>	<u>Amount of Grease to Add</u>
Up to 2-3/8	1-1/4 cu. in.
Above 2-3/8 to 3	2
Above 3 to 4	3
Above 4 to 5	4

Note: 1 oz. = 1-1/4 cu. in.

#### Standard Westinghouse Grease #55272-BA Ordering Data

8 oz. tube	S# 1781386
1 lb. can	S# 1781387
5 lb. can	S# 1781388
35 lb. can	S# 1781389

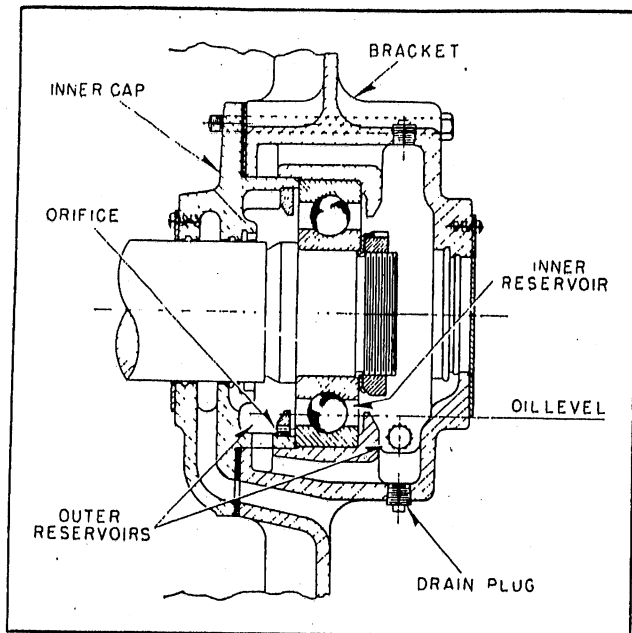

Figure 5 Typical Ball Bearing (Oil Lubricated)

## OIL LUBRICATED BALL BEARINGS

### Lubrication

Before starting the motor, fill both oil reservoirs with a good grade of lubricating oil having a viscosity of 180 to 220 SSU at 100°F. (equivalent to S.A.E. #10). This should be done by pouring oil in through the filling cup until no more oil can be added. Keep filling cup closed by screwing in the hinged, threaded, plug tightly with the fingers.

On motors equipped with constant level oilers, fill the bottle with oil, insert quickly into place. Repeat until bottle remains partially filled. It is necessary that oil be visible in the bottle for proper bearing lubrication. Do not operate motor unless bottle is partially filled with oil.

If any oil is accidentally spilled on the bracket, it should be wiped off with a rag. Do not allow oil to get on the windings which may lead to deterioration of the insulation.

### Change of Oil

Every six months the reservoir should be drained by removing the drain plug

located at the bottom of the oil sump in the casting. Refill with fresh, clean oil.

### Lubricating System

Fig. 5 is a cross section of the bearing assembly. Circulation of oil through the bearing is maintained by the pumping action of the bearing itself. The oil level is maintained at about the center of the lowest ball. The bearing is located in an inner oil reservoir separated from the outer and larger reservoirs. When running, the bearing throws oil from the inner to the outer reservoirs; new oil is fed to the bearing through the orifice, at a controlled rate depending on the orifice size. So long as the oil level is maintained, the bearing is assured of an adequate and constant supply of oil at starting and at any speed.

No oil need be added till the oil drops below the full level, which is 1/8 inch below the top of the overflow gauge. Do not flood the bearings. After oiling, close the cover of the overflow gauge.

## DISASSEMBLY OF BALL BEARING MOTORS

### Cleanliness

Since ball and roller bearings are sensitive to small amounts of dirt, they must be protected at all times. When necessary to disassemble the bearing housing, first thoroughly remove all dirt from the adjacent part, so no dirt will fall upon the bearing or into the bearing housing.

### Removal of End Brackets

The end brackets can be removed by unscrewing all the bolts that hold the bracket to the frame and the bolts that hold the inner cap to the bearing housing. Upon removing the brackets, the rotor can be removed.

### Removal of Bearings

The bearings can be removed using a wheel puller or similar device. The inner



cap should be slid along the shaft away from the bearing so that the puller can be used against the inner race of the bearing. If the bearing is pulled by pressure against the outer race, it will be ruined.

#### Replacing of Bearings

To replace a bearing on the shaft, be sure that the bearing seat is free of dirt, nicks or burrs. Heat the bearing in an oven or clean oil bath for 1/2 hour at a temperature of approximately 190°F but not to exceed 212°F at any time. Slip the hot bearing on the shaft and hold in place until bearing has cooled appreciably. Do not assemble in bracket until bearing has cooled.

#### SLEEVE BEARINGS

##### Lubrication

Before starting the motor, fill both oil reservoirs with a good grade of lubricating oil having a viscosity of 180 to 220 SSU at 100°F (equivalent to S.A.E. #10). This should be done by pouring oil in through the filling cup until no more oil can be added. Keep filling cup closed by screwing in the hinged, threaded plug tightly with the fingers.

On motors equipped with constant level oilers, fill the bottle with oil, insert quickly into place. Repeat until bottle remains partially filled. It is necessary that oil be visible in the bottle for proper bearing lubrication. Do not operate motor unless bottle is partially filled with oil.

If any oil is accidentally spilled on the bracket, it should be wiped off with a rag. Do not allow oil to get on the windings which may lead to deterioration of the insulation.

The construction of the sleeve bearing is such as to require no flushing-out during normal service. At intervals of about two years in average service, or during general overhaul periods, remove the bracket and thoroughly wash out the bearing housings, using hot kerosene oil and compressed air if available. Always check to be sure oil rings are turning during operation, and check rate of temperature rise at initial

start. If temperature continues to rise rapidly it usually indicates trouble.

#### Removing Solid Sleeve Bearings

If it becomes necessary to remove sleeve bearings, proceed as follows:

1. Drain oil by removing drain plugs from bearing housing.
2. Remove oil ring inspection cover.
3. Remove bolts holding the bracket to the frame and force the bracket loose by striking it with a soft mallet in a direction parallel to the shaft. Pull bracket off shaft.
4. Remove bearing locking screw and oil ring keeper.
5. Remove outer and inner bearing caps. (Group 1 and 2 of Fig. 6).
6. Turn bracket 180° so that oil ring will drop through oil ring slot in the bearing. Position or hold with a piece of wire the oil ring away from bearing so that bearing can be removed without damage to oil ring.
7. Tap the bearing out toward the inside by placing a bearing driver or rod against bearing shoulder. (See Fig. 6).

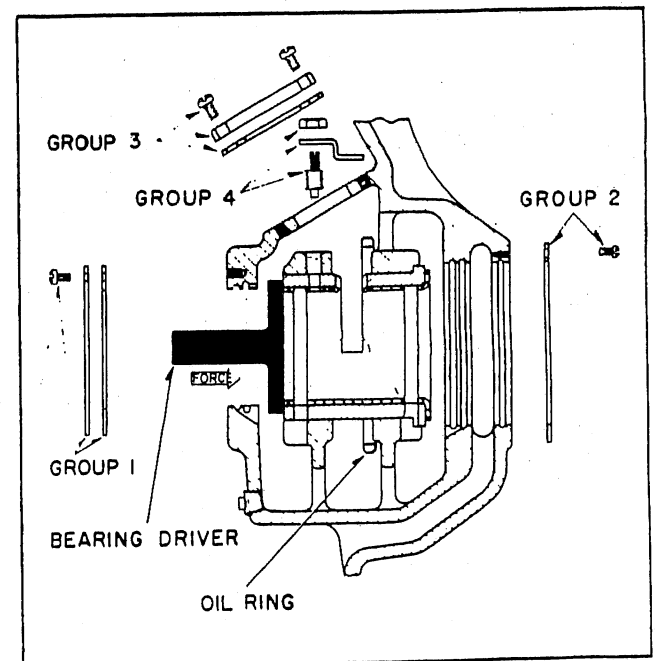

Figure 6 Detail of Solid Sleeve Bearing

8. To replace, reverse the above procedure, except take care to keep the oil ring clear of the bearing as before and preferably assemble the bracket on the shaft upside down so that the oil ring will not be caught and damaged between the end of the shaft and the side of the oil ring slot in the housing. Before bolting the bracket in place, it must be revolved on the shaft to the correct position. After bolting in place check to see that the oil ring revolves with the shaft.

#### Removing Split Sleeve Bearings

If it becomes necessary to remove split sleeve bearing proceed as follows:

1. Remove airshield bolts on upper half of bracket only. Do not disturb position of solid airshield by removing airshield bolts in lower half of bracket unless bottom half of bracket is also to be removed.
2. Remove bolts holding upper half of bracket to frame.
3. Remove bolts holding bracket halves together at split.
4. Remove dowel bolts mounted through bracket halves by tightening up nuts.
5. Break sealing compound between bracket halves by bumping along split and frame fit with a copper or brass mallet.
6. Slide upper half of bracket axially back from frame to clear bracket fit.
7. Lift off upper half of bracket. Use bracket bolts in bracket holes for lifting lugs.

8. Lift off upper half of sleeve bearing from lower half. Bearing halves are held together by four dowel pins and slight pressure straight up will remove upper half. It may be necessary to use chisel at split to break sealing compound.

9. To remove lower half of bearing rotate bearing 180° around shaft and lift out. To rotate bearing apply a series of light bumps on outer edge of bearing shoulder with soft material rod and light hammer.

10. To replace reverse above procedure except be sure all old sealing compound is removed from both halves of parts. To remove sealing compound first scrape then use a coal tar solvent such as Xylol or Toluol. Do not apply new sealing compound to bearings or bracket halves until ready to join both halves as compound sets up quickly. When joining brackets be sure to connect first with dowel bolts.

11. To reseal splits use Permatex\* #2.

#### RENEWAL PARTS

Renewal Parts information may be obtained from the nearest Westinghouse Sales Office. Be sure to name the part or parts required (see Figs. 3 and 4) and give the complete nameplate reading on the motor for positive identification.

---

\*Registered Trademark